

GRID LOCATION	BOTTOM ELEVATION
G/4	24'-5"1/2

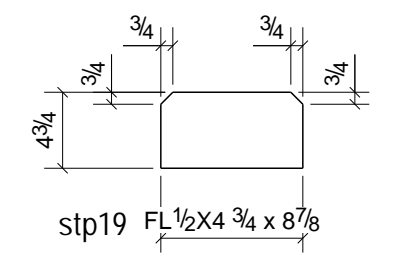

## ONE - COLUMN - C15

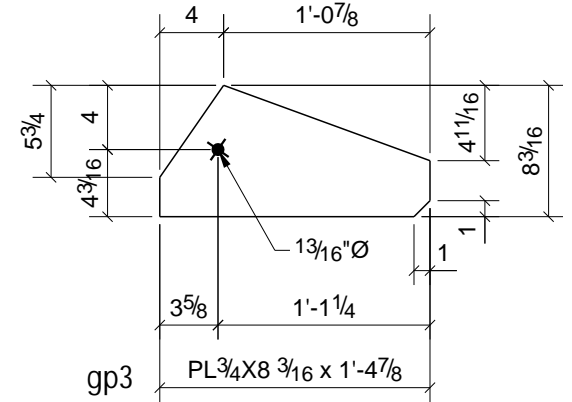
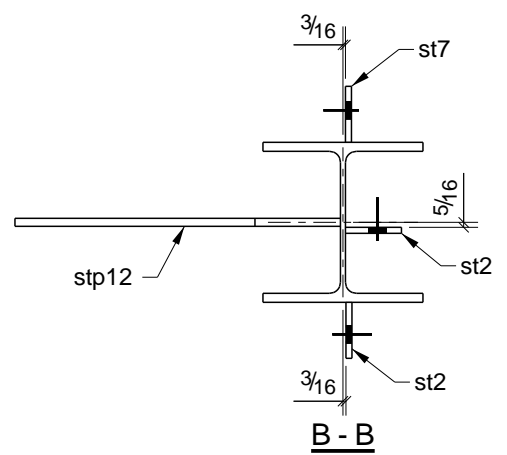
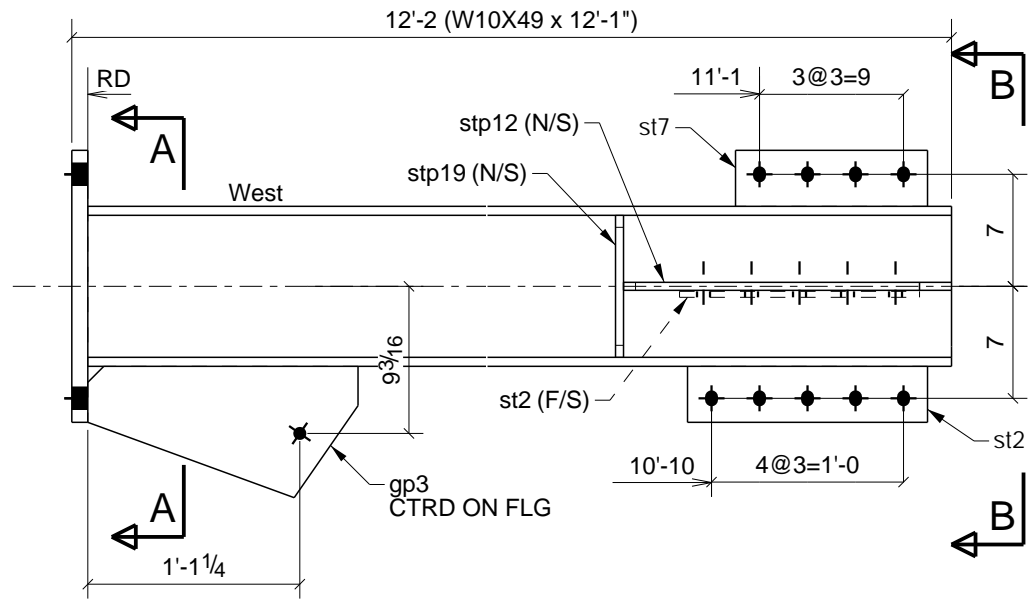
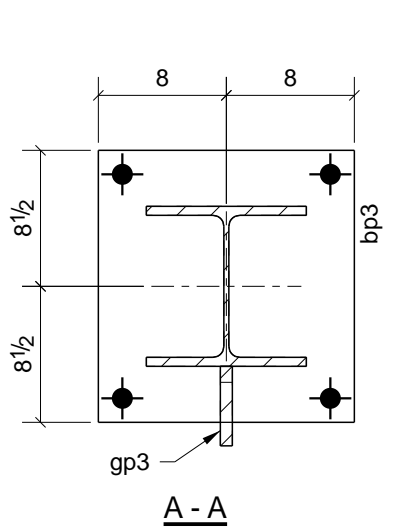
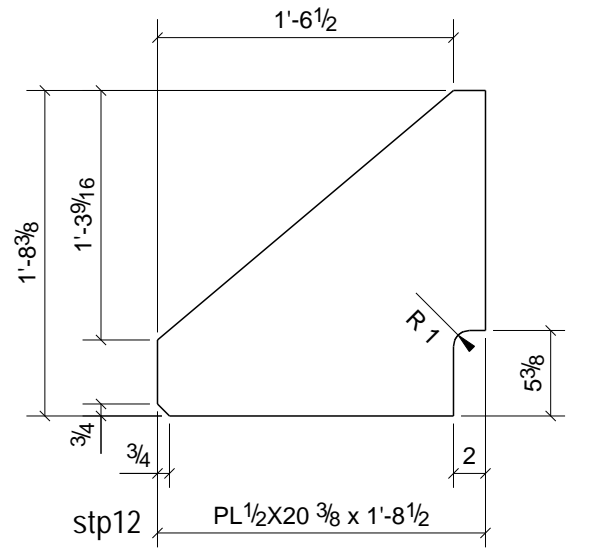
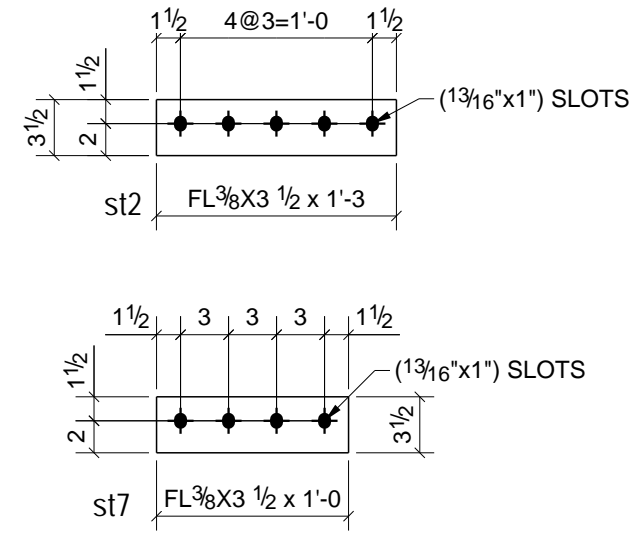
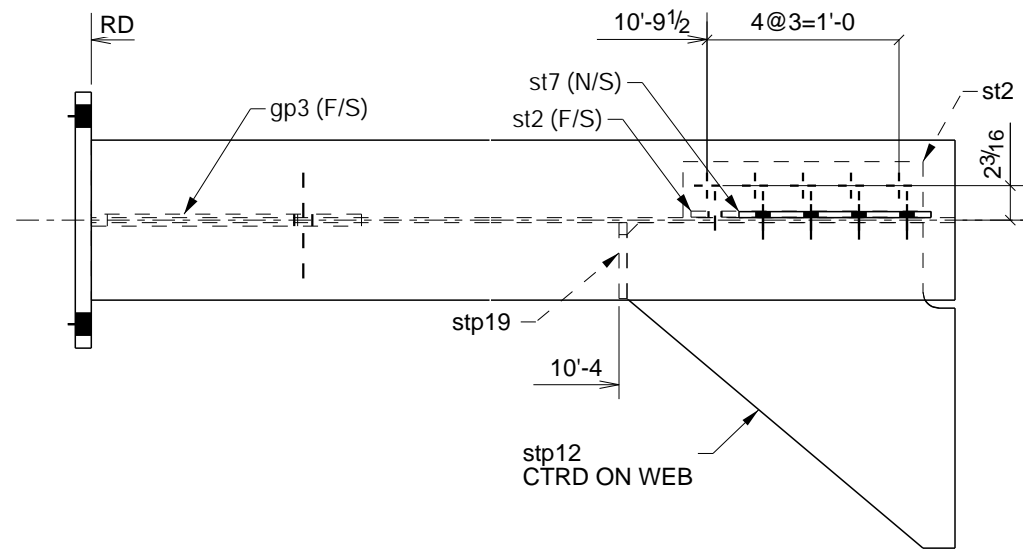
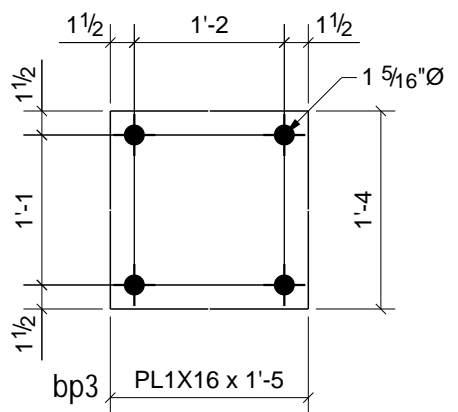

BILL OF MATERIAL							
Qty Ea.	Qty Tot	Piece Mark	Description	Length	Weight Total	Remarks	Adv Mill #
	1	C15	COLUMN				
1	1		W10X49	12'-1"	592	SQ-2	A992
1	1	bp3	PL1"X16"	1'-5"	77		A36
1	1	gp3	PL3/4"X8 3/16"	1'-4 7/8"	20		A36
2	2	st2	FL3/8"X3 1/2"	1'-3"	11		A36
1	1	st7	FL3/8"X3 1/2"	1'-0"	4		A36
1	1	stp12	PL1/2"X20 3/8"	1'-8 1/2"	37		A36
1	1	stp19	FL1/2"X4 3/4"	0'-8 7/8"	6		A36

12/07/2019	3	RE-ISSUED FOR FABRICATION	DAP
11/18/2019	2	ISSUED FOR FABRICATION	DAP
DATE	NO.	DESCRIPTION	BY
PROJECT NAME <b>1 NEWCOMB PL</b>			
LOCATION <b>1 NEWCOMB STREET, BOSTON MA</b>			
CONTRACTOR			
ARCHITECT			
DESCRIPTION <b>COLUMN</b>		DATE 11/13/2019	JOB No. <b>18-038</b>
		DRAWN BY DAP	DRG No. <b>C15</b>